

Uni 602M

UNI COLLECTION:

Uni 550, Uni 378, Uni 550M, Uni 378B, Uni 378M, Uni 378B-M, Uni 380, Uni 380M, Uni 380B, Uni 380B-M, Uni 562, Uni 562M, Uni386, Uni 386M, Uni 602, Uni 602M, Uni 551, Uni 551M, Uni 552, Uni552M, Uni552-G, Uni 552M-G, Uni 552T, Uni 552G-T, Uni 558-DP, Uni 558M-DP, Uni 558-DR, Uni 553, Uni 558M-DR, Uni 553M, Uni 577, Uni 577M, Trolley 536, Uni 544, Uni 391, Uni 565, Uni 391M, Uni 393, Uni 393M, Uni 220, Uni 221, Uni 223, Uni 222,

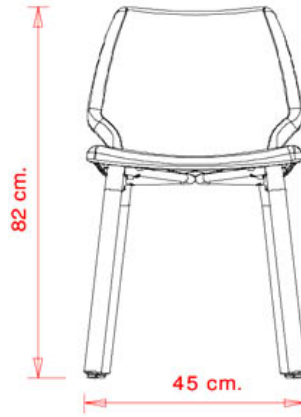

Chair with beech wood frame, 4 rounded legs. Upholstered polypropylene shell.

WEIGHT

6,65 Kg

PACK

0,24 m³

PIECES PER BOX

1

FINISHES SEATING

TE FABRICS



Melva
+ 5 colors



Fortis + 8 colori

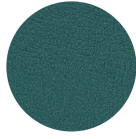

Inca
+ 14 colors



Amsterdam
+ 8 colors

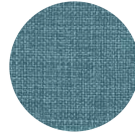

Medley Gabriel
+ 15 colors

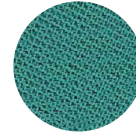

Chili Gabriel
+ 8 colors

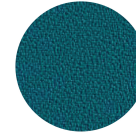

Mirage
+ 8 colors



Convert
+ 7 colors



Fenice
+ 8 colors



Mood Gabriel
+ 8 colors



Valencia
+ 14 colors

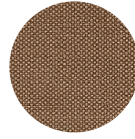

Reviva Hero
+ 10 colors



Fabthirty Rubelli
+ 8 colors



Ocean Mastrotto
+ 15 colors

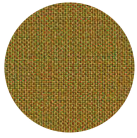

Remix 3 Kvadrat
+ 15 colors

PP POLYPROPYLENE

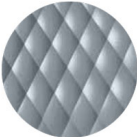

NCS S4005-B20G
Squirrel grey
≡



NCS S4020-B10G Dusty blue
≡



NCS S6502-R Clay
≡

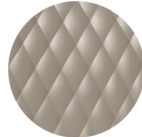

NCS S4005-Y50R Turtle-dove
≡

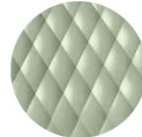

NCS S3010-G50Y
Pistachio
≡

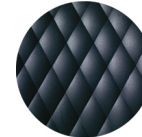

NCS S7502-B
Anthracite grey
≡



RAL 9005 Jet black
≡



NCS S3060-Y80R
Coral red
≡



NCS S0502-B
Traffic white
≡

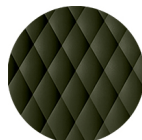

NCS S7020-G50Y
Olive green
☀

NOTE

Resources

3ds  | dwg 

Shell in **olive green** is made of **100% recycled polypropylene** from industrial waste.

FRAMES

LE WOOD



Beech | Honey stained



Beech | Chesnut stained



Beech | Dark brown stained



beech | Black stained

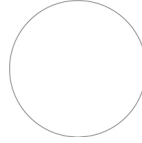

Beech | Stained according to sample

USES

coffee & restaurants, hotels, retail.