

Contemporary living

# Groove #1



**DOMINGO**<sup>®</sup>

Contemporary living

# Groove

**“Non può esserci nessuna nuova nota. Se guardi la tastiera, tutte le note sono già lì. Ma se dai a una nota un particolare significato, quella nota avrà un suono diverso”**

**“The piano ain't got no wrong notes. It can't be any new notes. When you look at the keyboard, all the notes are there already, but if you mean a note enough, it will sound different”**

**Thelonious Monk**

**IDOMINGO®**



Groove è una selezione di divani, poltrone e tavolini contemporanei minimalisti e sofisticati. Forme e materiali si accordano in una ritmica delicata, frutto di una ricerca attenta e di un'esecuzione accurata, ove la bellezza si genera attraverso segni di stile e dettagli accattivanti.

Groove is a selection of refined minimalist sofas, armchairs and coffee tables. Shapes and materials get in tune with a delicate rhythm that is the outcome of a painstaking research and a meticulous execution where beauty flows through stylish and captivating details.

Divani  
Sofas

**Barlow** 10

**Cox** 32

**Crosby** 48

**Foy** 68

**Tilton** 88

Poltrone e pouf  
Armchairs and poufs

**Dinah** 106

**Parker** 107

**Duke** 108

**Dizzy** 109

**Billie** 110

**Frank** 111

**Joe** 112

Tavolini  
Small tables

**Tabbal** 116

**Taborn** 118

**Priamo** 120

**Tablette** 122

**Warhol** 124

**Ceo** 126

**Febe** 128

**Rea** 130

**Teti** 132

**Zaikin** 134

Divani  
Sofas

**Barlow** 10



**Cox** 32



**Crosby** 48



**Foy** 68



**Tilton** 88



Poltrone e pouf  
Armchairs and poufs

**Dinah** 106



**Parker** 107



**Duke** 108



**Dizzy** 109



**Billie** 110



**Frank** 111



**Joe** 112



Tavolini  
Small tables

**Tabbal** 116



**Taborn** 118



**Priamo** 120



**Tablette** 122



**Warhol** 124



**Ceo** 126



**Febe** 128



**Rea** 130



**Teti** 132



**Zaikin** 134



# Divani Sofas

Il divano è un oggetto rassicurante,  
un territorio accogliente e confortante,  
che aspetta solo di essere abitato.

Sofas are reassuring  
objects, a welcoming  
and comforting territory  
waiting to be inhabited.

# Barlow

Barlow è la forza della leggerezza, la raffinatezza dell'essenziale e la delicatezza di un dettaglio quasi impercettibile. Una collezione componibile le cui geometrie rigorose, interrotte da morbidezze inaspettate e arricchite da esercizi di sartorialità, generano vibrazioni profonde nei puristi delle forme minimaliste.

Barlow is the strength of lightness, the elegance of essence and the subtlety of an almost imperceptible detail. A modular collection whose rigorous geometries, interrupted by unexpected softness and enriched by tailoring expertise, generate deep vibrations in purists who favor a minimalist style.



Divani/Sofas  
**Barlow**  
Composizione 1  
Composizione 1

Tavolini/  
Small tables  
**Ceo**

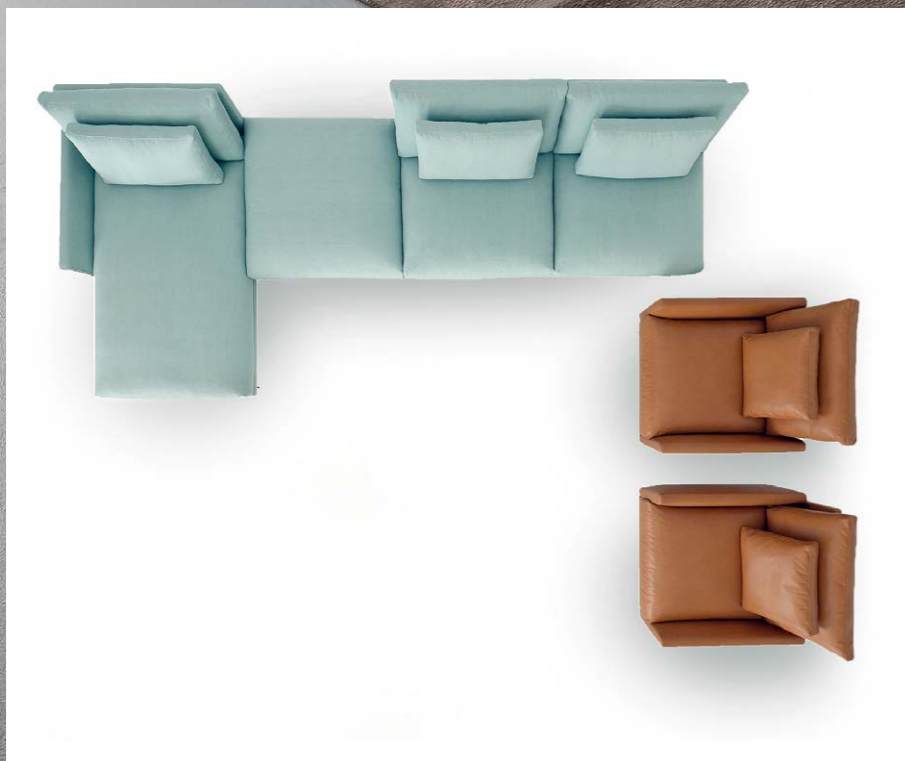



Il dettaglio del bracciolo con inserto in pelle è una scelta di stile che si inserisce con naturalezza nelle linee essenziali di Barlow, un valore aggiunto alle sue geometrie rigorose.

The leather insert in the armrest is a stylish detail that fits naturally into Barlow's essential lines, an added value to its rigorous geometries.











**Barlow**  
Composizione 3  
Composition 3

Poltrona/  
Armchair  
**Parker**

Tavolini/  
Small tables  
**Rea**  
**Ceo**





**Barlow**  
Composizione 3  
Composition 3

Poltrona/  
Armchair  
**Parker**

Tavolini/  
Small tables  
**Rea**  
**Ceo**





Divani/Sofas  
**Barlow**  
Divano tre posti  
Three seater sofa



Divani/Sofas  
**Barlow**  
Composizione 3  
Composition 3

Tavolini/  
Small tables  
**Rea**  
**Ceo**

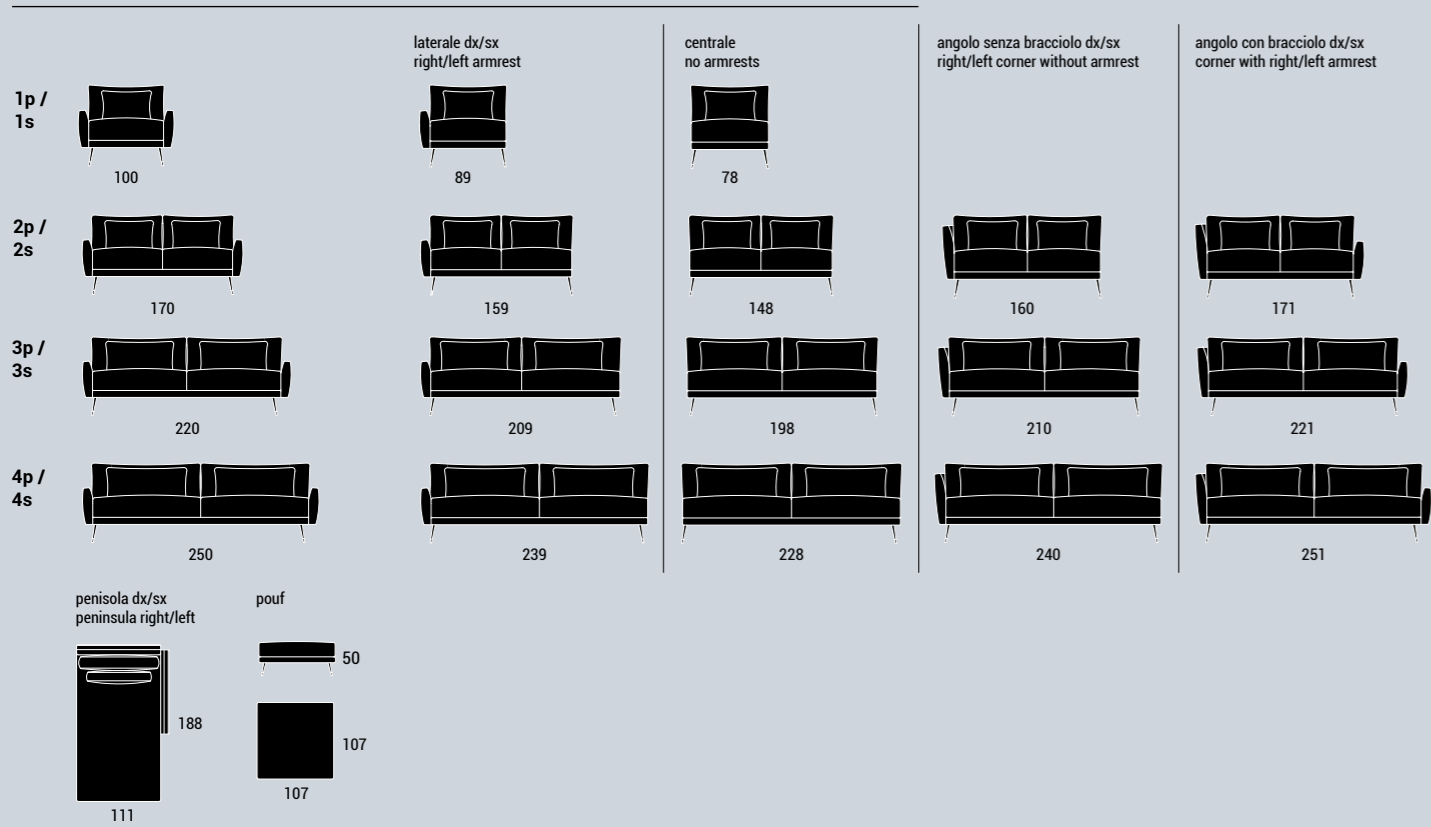

**Composizioni suggerite**  
Suggested configurations

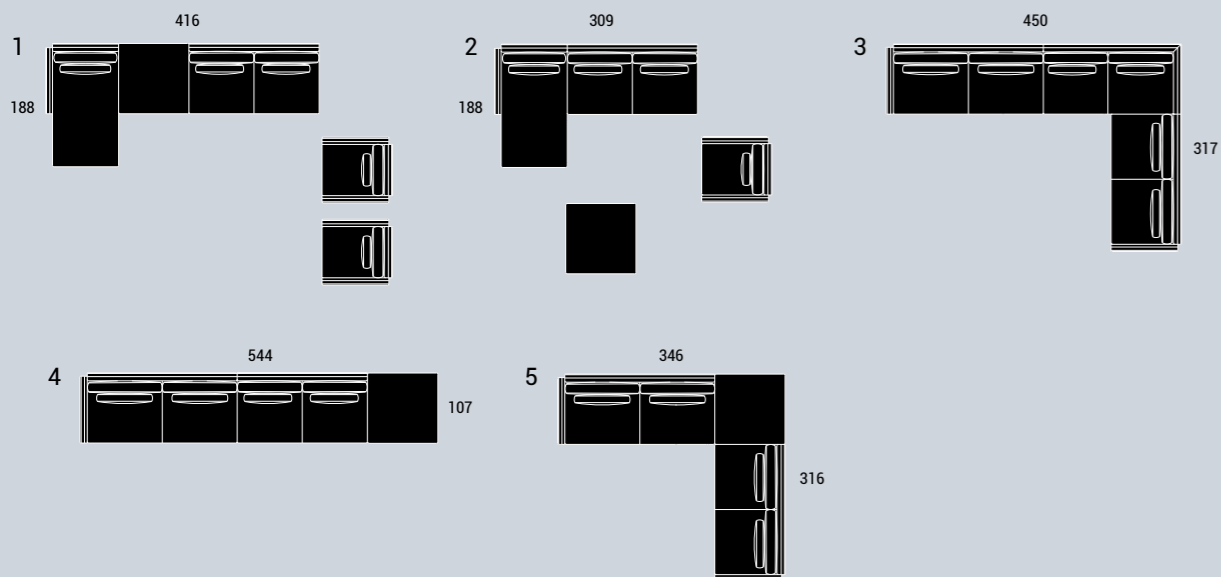

- 1 penisola sx + pouf + 3P centrale + 2x 1P  
peninsula left + pouf + 3S no armrests + 2x 1S
- 2 penisola sx + 3P centrale + 1P + pouf  
peninsula left + 3S no armrests + 1S + pouf
- 3 3P sx + 2P angolo senza bracciolo dx + 3P dx  
3S left + 2S right corner without armrest + 3S right
- 4 4P sx + 3P centrale + pouf  
4S left + 3S no armrests + pouf
- 5 4P sx + pouf + 3P dx  
4S left + pouf + 3S right

Struttura in legno di abete e multistrato di pioppo in vari spessori, cl. E1 a bassa emissione di formaldeide. Imbottitura in poliuretano espanso indeformabile in densità da 30 a 40 kg/m<sup>3</sup> e ovatta in poliestere. Cinghie elastiche da 80 mm. Piedi in metallo e acciaio inox. Resine e collanti utilizzati sono privi di sostanze ozonolesive, CFC e solventi clorurati. Tutti i materiali impiegati rispettano la normativa EU 91/156 per lo smaltimento dei rifiuti. Prodotto lavorato interamente a mano in Italia.

Fir wood and poplar plywood frame (thickness varies), cl. E1 low formaldehyde emission. Crushproof polyurethane foam padding (density varies from 30 to 40 kg/m<sup>3</sup>) and polyester wadding. 80-mm elastic straps. Metal and inox steel legs. The resins and adhesives employed are free of ozone-depleting substances, CFCs and chlorinated solvents. All materials comply with EU regulation 91/156 for waste disposal. Manufactured entirely by hand in Italy.

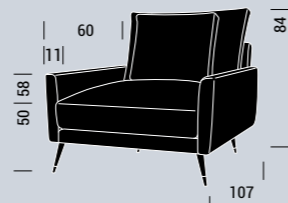

# Barlow



1 penisola sx + pouf + 3P centrale + 2x 1P  
peninsula left + pouf + 3S no armrests + 2x 1S



3 3P sx + 2P angolo senza bracciolo dx + 3P dx  
3S left + 2S corner right without armrest + 3S right

**P 115**  
Piedi Feet



50L  
Nero opaco liscio  
Smooth matt black  
Ral 9005

**Tessuti Fabrics**

Lino Linen

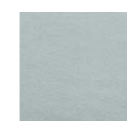

G077 col.09

Pelle Leather



Lux col.2434

Velluto Velvet



8336 col.53

**Bracciolo**  
Armrest

DI SERIE / STANDARD



Cucitura semplice  
Top-Stitched Seam

OPTIONAL



Con inserto in pelle  
With leather insert

**Cuscini seduta e schienale**  
Seat and backrest cushions

DI SERIE / STANDARD



Liscio tradizionale  
Cushion

OPTIONAL



Trapuntato  
Square quilted

**Dettaglio piedi**  
Feet detail



P 116  
H 18  
Piede in metallo verniciato  
nero con puntale in oro  
Black metal conical feet  
with golden cap



P 115  
H 18  
Piede in acciaio inox lucido  
Polished inox steel foot

**Finiture piede P 115**  
Foot P 115 finishings



01  
Bianco opaco goffrato  
Rough matt white  
Ral 9010



75L  
Delfino opaco liscio  
Smooth matt dolphin  
Ral 7038



11L  
Sand opaco liscio  
Smooth matt sand  
Ral 7038



127L  
Arabia opaco liscio  
Smooth matt arabia  
Ral 7038



92  
Bronzo antico opaco  
goffrato Rough matt  
old bronze Ral 8017



32L  
Ardesia opaco liscio  
Smooth matt slate  
Ral 7011



50L  
Nero opaco liscio  
Smooth matt black  
Ral 9005



# Cox

Cox si ispira alla tradizione delle sedute imbottite sfruttando in modo originale i diversi elementi costruttivi. La scelta di una nota di stile sul bracciolo e un'inflexione sullo schienale danno vita ad un divano al tempo stesso rassicurante ed ammiccante, la cui forza, oltre al piacere visivo è l'attrazione per l'esperienza di comfort che trasmette a chi lo osserva.

The inspiration for Cox was drawn directly from the tradition of upholstered furniture, but structural elements are slightly redefined. A sinuous detail in the armrest and the rigorous yet cushy pragmatism of the backrest connote a sofa that is both reassuring and fancy. Its strength, aside from aesthetic pleasure, is the irresistible idea of comfort it conveys.



Divani/Sofas  
**Cox**  
Composizione 1  
Composition 1

Tavolini/  
Small tables  
**Taborn**  
**Warhol**





Divano/Sofa  
**Cox**  
 Divano tre posti  
 Three seater sofa



Divani/Sofas  
**Cox**  
 Composizione 1  
 Composition 1

Poltrona/  
 Armchair  
**Duke**

Tavolini/  
 Small tables  
**Taborn**  
**Warhol**

Divani/Sofas  
**Cox**  
Composizione 1  
Composition 1

Poltrona/  
Armchair  
**Duke**

Tavolini/  
Small tables  
**Taborn**  
**Warhol**





Divano/Sofa  
**Cox**  
Poltrona  
Armchair



Divani/Sofas  
**Cox**  
Composizione 1  
Composizione 1

Poltrona/  
Armchair  
**Duke**

Tavolini/  
Small tables  
**Taborn**  
**Warhol**



Divano/Sofa  
**Cox**  
Pouf

Divani/Sofas  
**Cox**  
Composizione 2  
Composition 2



Divani/Sofas  
**Cox**  
Composizione 5  
Composition 5



Divani/Sofas  
**Cox**  
Composizione 3  
Composition 3



Divani/Sofas  
**Cox**  
Composizione 4  
Composition 4

Tavolini/  
Small tables  
**Warhol**  
**Ceo**



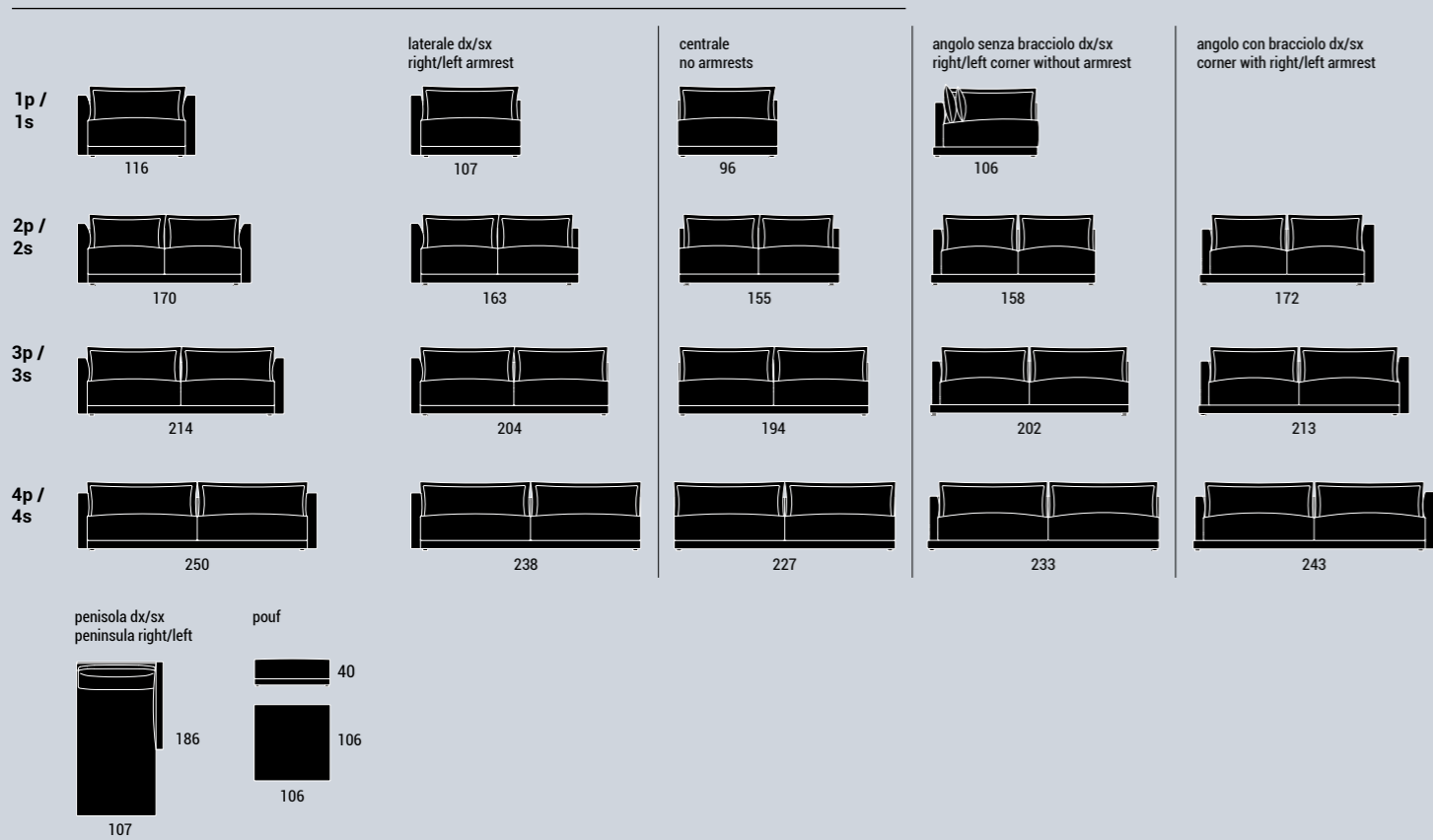

**Composizioni suggerite**  
Suggested configurations

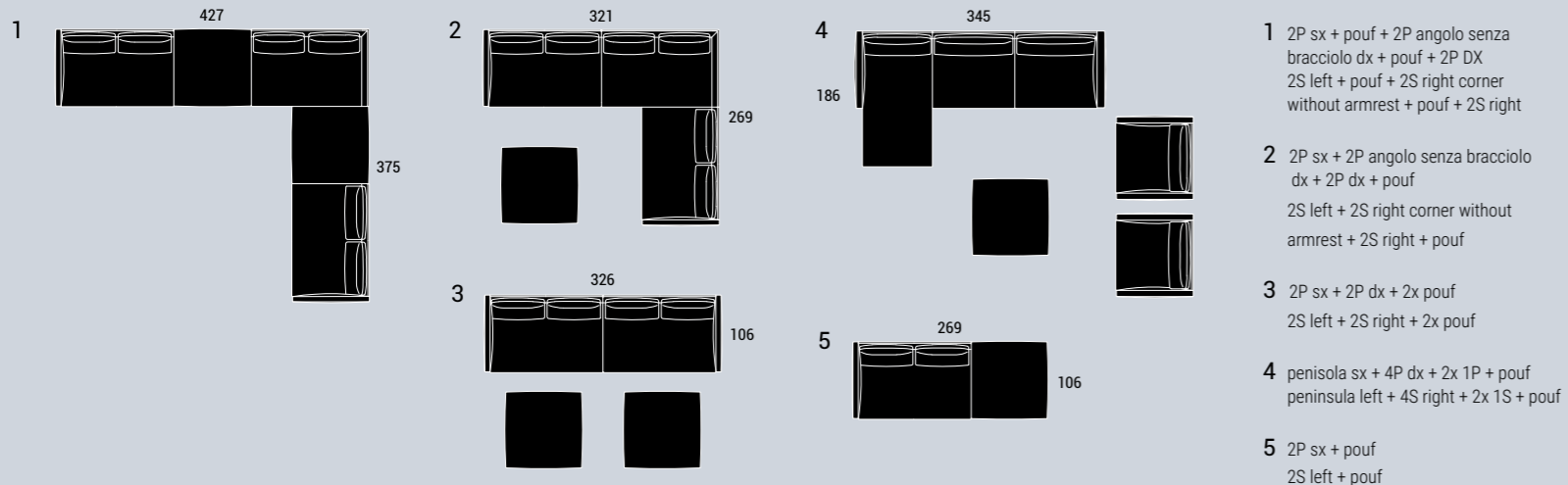

Struttura in legno di abete e multistrato di pioppo in vari spessori, cl. E1 a bassa emissione di formaldeide. Imbottitura in poliuretano espanso indeformabile in densità differenziate da 30 a 40 kg/m<sup>3</sup>, ovatta in poliester e piuma sintetica ecocompatibile. Piedi in legno. Resine e collanti utilizzati sono privi di sostanze ozonolesive, CFC e solventi clorurati. Tutti i materiali impiegati rispettano la normativa EU 91/156 per lo smaltimento dei rifiuti. Prodotto lavorato interamente a mano in Italia.

Fir wood and poplar plywood frame (thickness varies), cl. E1 low formaldehyde emission. Non-deformable polyurethane foam padding (density varies from 30 to 40 kg/m<sup>3</sup>), polyester wadding and eco-friendly synthetic down. Wooden feet. The resins and adhesives employed are free of ozone-depleting substances, CFCs and chlorinated solvents. All materials used comply with EU 91/156 regulations for waste disposal. Manufactured entirely by hand in Italy.

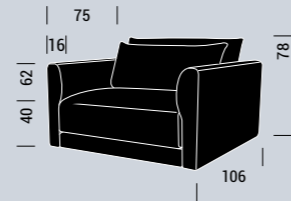

**Cox**



2P sx + pouf + 2P angolo senza bracciolo dx + pouf + 2P DX  
2S left + pouf + 2S right corner without armrest + pouf + 2S right



2P sx + 2P angolo senza bracciolo dx + 2P dx + pouf  
2S left + 2S right corner without armrest + 2S right + pouf



2P sx + 2P dx + 2x pouf  
2S left + 2S right + 2x pouf



2P sx + pouf  
2S left + pouf

**Tessuti Fabrics**



L1649 col.04



penisola sx + 4P dx + 2x 1P + pouf  
peninsula left + 4S right + 2x 1S + pouf

**Tessuti Fabrics**

Ciniglia Chenille



M036 col.20

Jaquard



M039 col.01

Velluto Velvet



8336 col.55

**Dettaglio piede**  
Foot detail



P 59  
H 2

Piede in legno tinto nero  
Black stained wooden foot



# Crosby

L'improvvisazione può essere una necessità o una virtù, in alcune situazioni è la formula migliore per godere appieno degli spazi e godere la socialità. Crosby è la soluzione senza regole, il divano ideale perché mai definitivo. Pochi elementi costruttivi per dare libera espressione agli istinti creativi e funzionali, restando focalizzati sulle morbidezze e sul comfort.

Improvisation may spring out of need or virtue; when socializing and enjoying the setting is the point, improvisation is the key. Crosby is a rule-free furnishing solution, the ideal sofa as it is never definite. Its essential structural elements leave absolute freedom of expression to creative and functional instincts while remaining focused on softness and comfort.



Divani/Sofas  
**Crosby**  
Composizione 1  
Composition 1

Tavolini/  
Small tables  
**Priamo**









Divani/Sofas  
**Crosby**  
Composizione 4  
Composition 4

Tavolino/  
Small table  
**Tablette**

Pouf  
**Billie**



Divani/Sofas  
**Crosby**  
Composizione 5  
Composition 5



Divani/Sofas  
**Crosby**  
Composizione 6  
Composition 6



## Moduli/Modules

### Sedute/Seats

Pouf 100x100



Pouf 100x50



Pouf 60x50



### Strutture/Frames

Schienale singolo  
Single backrest



Schienale angolare  
Corner backrest



Raccordo sedute  
Seat fastening module



### Cuscini schienale/Backrest cushions

Large



Small



### Accessori/Accessories

Vassoio per pouf 60x50  
Tray for pouf 60x50



## Componibilità/Modularity

Pouf 100x100



+

Schienale singolo  
Single backrest

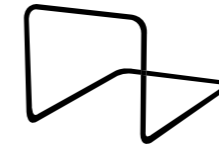

+



+

Cuscino schienale large  
Large backrest cushion



Cuscino schienale small  
Small backrest cushion



=

Poltrona  
Armchair



Pouf 100x100



+

Schienale angolare  
Corner backrest

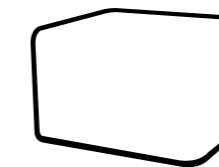

+



+

Cuscino schienale large  
Large backrest cushion



Cuscino schienale small  
Small backrest cushion



=

Angolo  
Corner





**Modularità/Modularity**

**Sistema di aggancio dello schienale/  
Backrest connection**

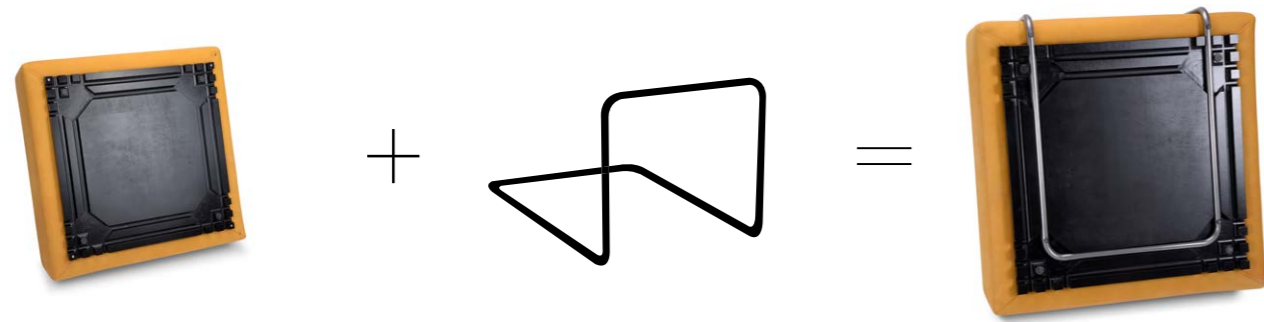

**Posizione dei cuscini schienale/  
Backrest cushion setting options**



**In appoggio**  
Stopped

**Ad incastro**  
Inserted

**Cerniera di fissaggio**  
Fastening zipper



**Sistema di raccordo sedute/  
Seats modulo fastening**

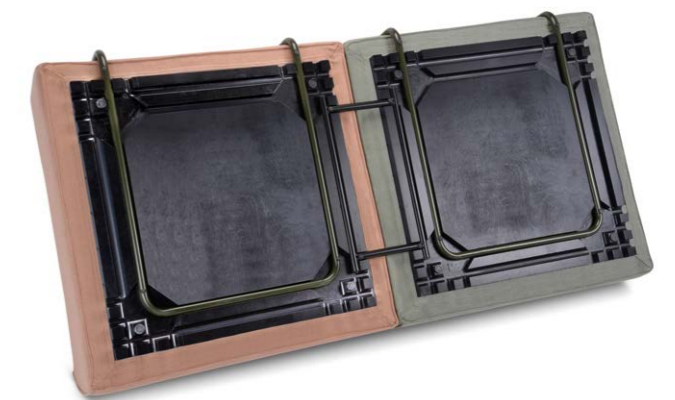
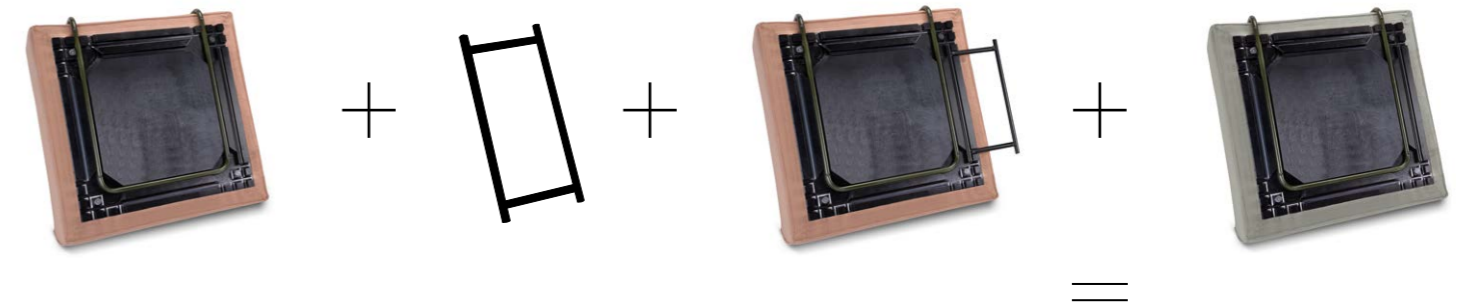

L'elemento di raccordo tiene unite le sedute accostate evitandone lo spostamento durante l'uso. Si innesta ad incastro nelle scanalature in legno della base senza uso di viti. La base è realizzata in legno pantografato, con scanalature per ospitare l'elemento di raccordo e i tubolari dello schienale.

The fastening module holds the seats together side by side, preventing them from shifting during use. It snaps into the wooden grooves on the bottom of the seats; no screws needed. The pantographed wood board bottom of the seat features grooves to accommodate the fastening module and the backrest metal support.



Moduli / Modules

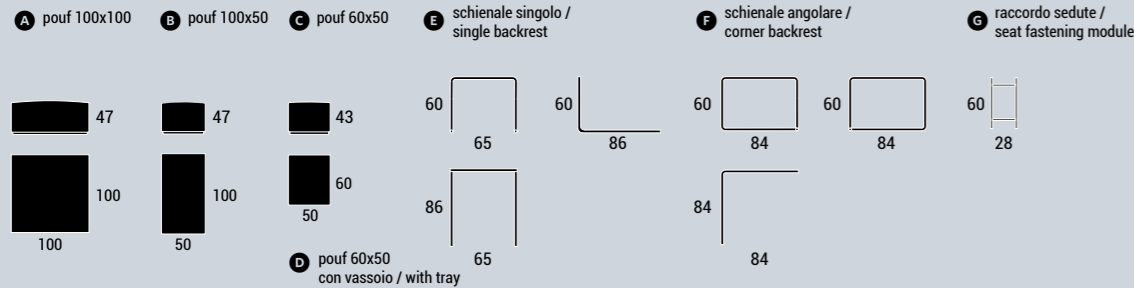

Composizioni suggerite / Suggested configurations

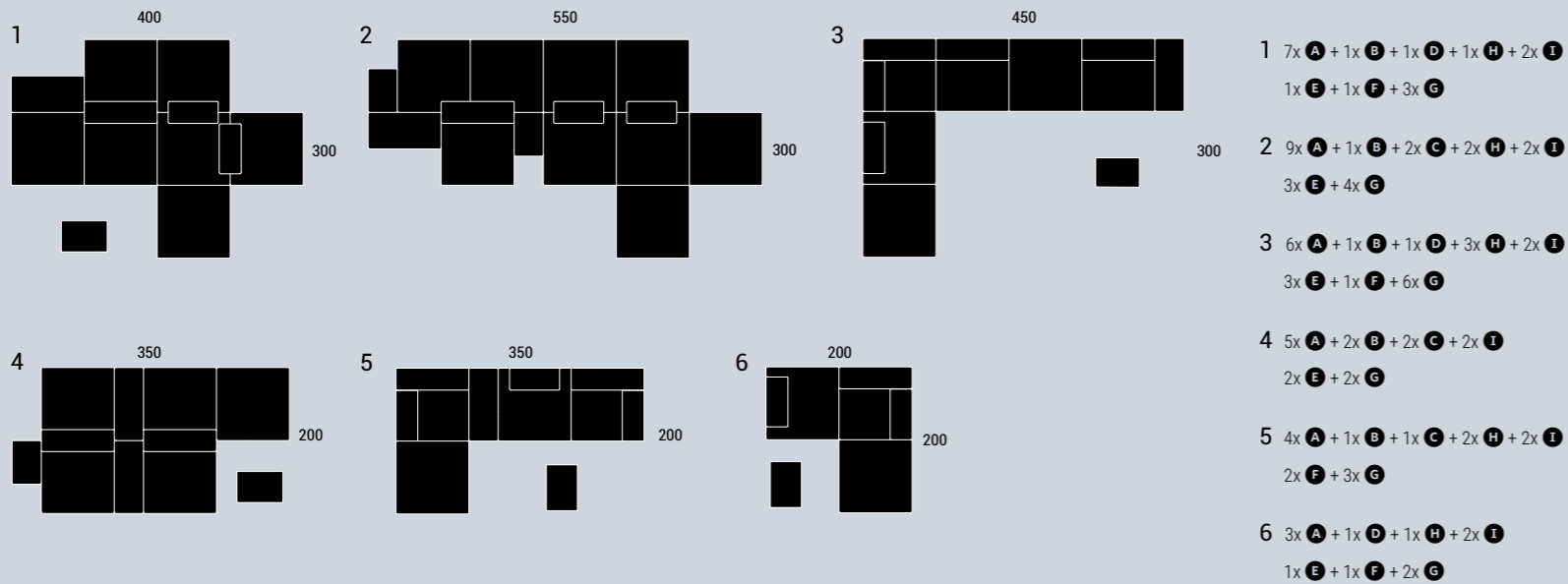

Profondità seduta in base al posizionamento del cuscino schienale  
Seating surface varies according to cushion setting

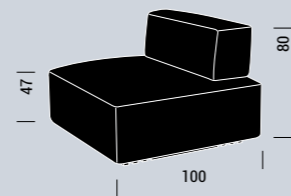

Struttura in legno di abete e multistrato di pioppo in vari spessori, cl. E1 a bassa emissione di formaldeide. Imbottitura in poliuretano espanso indeformabile in densità differenziate da 30 a 40 kg/m<sup>3</sup>, ovatta in poliestere e piuma sintetica ecocompatibile. Cinghie elastiche da 80 mm. Struttura in legno con scanalature pantografate CNC. Resine e collanti utilizzati sono privi di sostanze ozonolesive, CFC e solventi clorurati. Tutti i materiali impiegati rispettano la normativa EU 91/156 per lo smaltimento dei rifiuti. Prodotto lavorato interamente a mano in Italia.

Fir wood and poplar plywood frame (thickness varies), cl. E1 low formaldehyde emission. Non-deformable polyurethane foam padding (density varies from 30 to 40 kg/m<sup>3</sup>), polyester wadding and eco-friendly synthetic down. 80-mm elastic straps. Plywood base with CNC pantographed grooves. The resins and adhesives employed are free of ozone-depleting substances, CFCs and chlorinated solvents. All materials used comply with EU 91/156 regulations for waste disposal. Manufactured entirely by hand in Italy.

# Crosby



7x A 1x B 1x D 1x H 2x I  
1x E 1x F 3x G



9x A 1x B 2x C 2x H 2x I  
3x E 4x G



6x A 1x B 1x D 3x H 2x I  
3x E 1x F 6x G

Schienali e vassoio / Backrests and tray

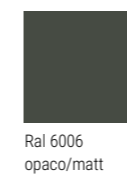

Tessuti Fabrics

Cotone Jacquard Jacquard Cotton

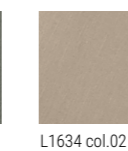
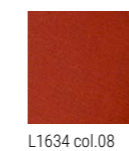
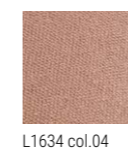

Dettaglio cuciture / Stitching detail

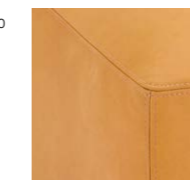

Dettaglio piede / Foot detail



Finiture schienali e vassoio pouf 60x50 / Backrests and tray for pouf 60x50 finishings

DI SERIE / STANDARD

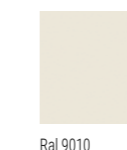
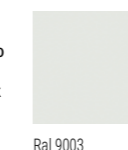

OPTIONAL



5x A 2x B 2x C 2x I  
2x E 2x G



4x A 1x B 1x C 2x H 2x I  
2x F 3x G



3x A 1x D 1x H 2x I  
1x E 1x F 2x G

Schienali e vassoio / Backrests and tray



Tessuti Fabrics

Pelle Leather



# Foy

design **Baldessari e Baldessari**

Disegnare un divano è come raccontare una storia. In questa storia le forme fungono da linee di raccordo tra un pensiero e i materiali che plasmano un nido. Il nido dove ci rifugiamo per farci accogliere e coccolare, per condividere o isolarci. Un nido che, anche quando non utilizzato, deve emanare bellezza. Questo è Foy, il divano degli abbracci.

Designing a sofa is like telling a story. In this story, shapes act as connecting lines between a thought and the materials that make a nest, a cozy welcoming nest which is also a shelter from everything. A corner of the home that radiates beauty. This is Foy, the sofa of hugs.



Divani/Sofas  
**Foy**  
Divano tre posti-  
poltrona-pouf  
Three seater sofa-  
armchair-pouf

Tavolino/  
Small table  
**Priamo**





Divani/Sofas  
**Foy**  
Divano tre posti-  
poltrona  
Three seater sofa-  
armchair  
Tavolino/  
Small table  
**Priamo**



Divani/Sofas  
**Foy**  
 Divano tre posti-  
 poltrona  
 Three seater sofa-  
 armchair

Tavolino/  
 Small table  
**Priamo**





Divani/Sofas  
**Foy**  
Divano tre posti-  
poltrona  
Three seater sofa-  
armchair

Tavolino/  
Small table  
**Priamo**



Divano/Sofa  
**Foy**  
Poltrona  
Armchair







Divani/Sofas  
**Foy**  
Divano due posti-pouf  
Two seater sofa-pouf

Tavolini/  
Small tables  
**Taborn**



Divano/Sofa  
**Foy**  
Divano due posti  
Two seater sofa



Divano/Sofa  
**Foy**  
Divano tre posti  
Three seater sofa



1p /  
1s



102

2p /  
2s



192

3p /  
3s



235

Pouf



45



87

120

Struttura in legno di abete e multistrato di pioppo in vari spessori, cl. E1 a bassa emissione di formaldeide. Imbottitura in poliuretano espanso indeformabile in densità differenziate da 30 a 40 kg/m³, ovatta in poliestere e piuma sintetica ecocompatibile. Cinghie elastiche da 80 mm. Piedi in legno. Resine e collanti utilizzati sono privi di sostanze ozonolesive, CFC e solventi clorurati. Tutti i materiali impiegati rispettano la normativa EU 91/156 per lo smaltimento dei rifiuti. Prodotto lavorato interamente a mano in Italia.

Fir wood and poplar plywood frame (thickness varies), cl. E1 low formaldehyde emission. Non-deformable polyurethane foam padding (density varies from 30 to 40 kg/m³), polyester wadding and eco-friendly synthetic down. 80-mm elastic straps. Wooden legs. The resins and adhesives employed are free of ozone-depleting substances, CFCs and chlorinated solvents. All materials used comply with EU 91/156 regulations for waste disposal. Manufactured entirely by hand in Italy.

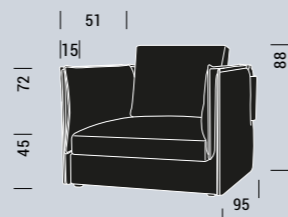

**Foy** design **Baldessari e Baldessari**



pouf + 3P + 1P  
pouf + 3S + 1S



2x 1P + 3P  
2x 1S + 3S



2P + pouf  
2S + pouf

**Tessuti Fabrics**

Pelle Nabuk  
Nabuk leather

Jaquard

Velluto  
Velvet



Retrò col.4018



2124 col.5

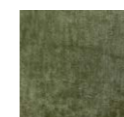

Sancho col.24

Pelle Nabuk  
Nabuk leather

Jaquard

Velluto  
Velvet



Retrò col.4018



2124 col.5

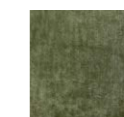

Sancho col.24

Velluto  
Velvet

Velluto di lino  
Linen velvet

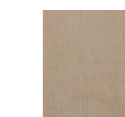

Sancho col.30



G077 col.18

Pelle Leather

Jaquard riciclato  
Recycled jaquard



Moon col.651



Raytent 3706 col.708

**Dettaglio piede  
Foot detail**



P 59  
H 2

Piede in legno  
tinto nero  
Black stained  
wooden foot

# Tilton

Tilton è la collezione degli incastri perfetti. Un Tetris contemporaneo costruito con soli tre elementi essenziali che si lasciano combinare all'infinito, mentre il gioco di equilibri tra geometrie e morbidezze cattura lo sguardo, soddisfacendo l'occhio attento ai dettagli.

Tilton is a series of square combinations, a contemporary Tetris built out of three essential modules that can be endlessly combined. The balanced interplay between geometry and softness catches the eye, harmonizing rigor and ease.



Divani/Sofas  
**Tilton**  
Composizione 1  
Composition 1

Poltrona/  
Armchair  
**Dizzy**

Pouf/Poufs  
**Billie**

Tavolini/  
Small tables  
**Taborn**



Divani/Sofas  
**Tilton**  
Composizione 1  
Composition 1

Pouf/Poufs  
**Billie**

Tavolini/  
Small tables  
**Taborn**







Quando i dettagli seguono  
il ritmo delle forme in modo  
piacevole e fluido, e le  
morbidezze si susseguono  
con armonia alle rigidità,  
tutto quello che resta da fare  
è lasciarsi trasportare dalla  
bellezza, nella bellezza.

When details follow  
the rhythm of shapes  
nicely and smoothly,  
and softness  
harmoniously alternates  
with stiffness,  
you may just let beauty  
carry you away.



Divani/Sofas  
**Tilton**  
Composizione 1  
Composition 1

Poufs  
**Billie**

Tavolini/  
Small tables  
**Taborn**

Divano/Sofa  
**Tilton**  
Poltrona  
Armchair



Divani/Sofas  
**Tilton**  
Composizione 2  
Composizione 2

Tavolini/  
Small tables  
**Zaikin**

## Modularità/Modularity



## Flessibilità/Flexibility



**Poltrona laterale dx/sx Armchair right/left armrest**



**Poltrona Armchair**



Pochi elementi per costruire una poltrona o un grande divano. Un pouf, una lamiera che funge da schienale o bracciolo, tre cuscini e tanta modularità. Il divano Tilton si presta a diverse configurazioni con la libertà di cambiare idea e gestirlo con semplicità.

The same few modules can make up an armchair or a large sofa: an ottoman, a metal sheet that can be a backrest- or an armrest, three cushions and lots of modularity. The Tilton sofa lends itself to different configurations and leaves you the freedom to change your mind - simple and easy.

**Moduli**  
**Modules**

- A** Pouf  
**B** centrale no armrests  
**C** laterale dx/sx right/left armrest

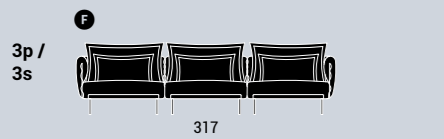
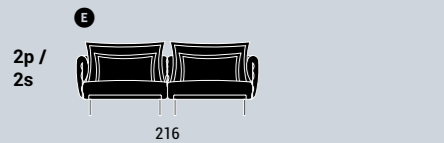
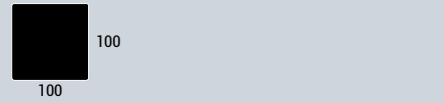

bracciolo / schienale  
armrest / backrest

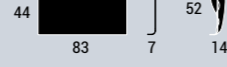

cuscino schienale  
backrest cushion

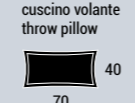

**Composizioni suggerite**  
**Suggested configurations**

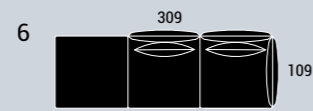
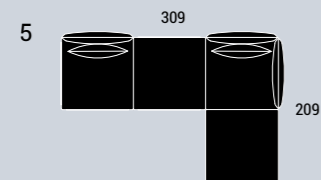
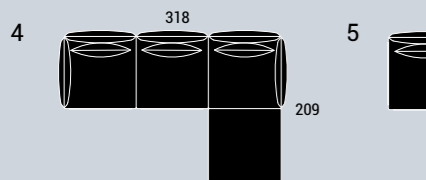
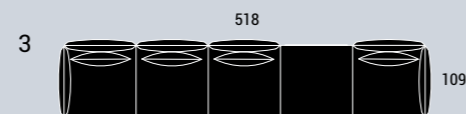
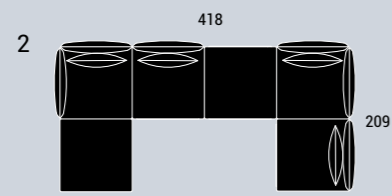
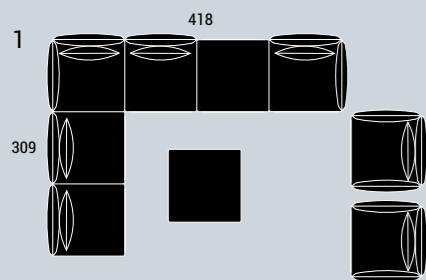

- 1 2x **A** + 3x **B** + 1x **C** laterale sx/left armrest + 1x **C** laterale dx/right armrest + 2x **D**
- 2 2x **A** + 2x **B** + 1x **C** laterale sx/left armrest + 1x **C** laterale dx/right armrest
- 3 1x **A** + 2x **B** + 1x **C** laterale sx/left armrest + 1x **C** laterale dx/right armrest
- 4 1x **A** + 1x **B** + 1x **C** laterale sx/left armrest + 1x **C** laterale dx/right armrest
- 5 2x **A** + 1x **B** + 1x **C** laterale dx/right armrest
- 6 1x **A** + 1x **B** + 1x **C** laterale dx/right armrest

Struttura in legno di abete e multistrato di pioppo in vari spessori, cl. E1 a bassa emissione di formaldeide. Imbottitura in poliuretano espanso indeformabile in densità differenziate da 30 a 40 kg/m³, ovatta in poliestere e piuma sintetica ecocompatibile. Struttura e piedi in metallo. Resine e collanti utilizzati sono privi di sostanze ozonolesive, CFC e solventi clorurati. Tutti i materiali impiegati rispettano la normativa EU 91/156 per lo smaltimento dei rifiuti. Prodotto lavorato interamente a mano in Italia.

Fir wood and poplar plywood frame (thickness varies), cl. E1 low formaldehyde emission. Non-deformable polyurethane foam padding (density varies from 30 to 40 kg/m³), polyester wadding and eco-friendly synthetic down. Metal frame and legs. The resins and adhesives employed are free of ozone-depleting substances, CFCs and chlorinated solvents. All materials used comply with EU 91/156 regulations for waste disposal. Manufactured entirely by hand in Italy.

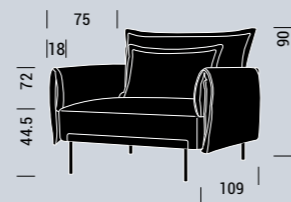

- 2x **A** 3x **B** 1x **C** sx/left  
1x **C** dx/right 2x **D**

**Piedi**  
**Feet**

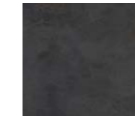

Grigio industriale  
Industrial grey

**Tessuti Fabrics**  
Jaquard lurex



G192 col.19



- 2x **A** 2x **B**  
1x **C** sx/left 1x **C** dx/right

**Piedi**  
**Feet**



Ral 9016  
lucido polished

**Tessuti Fabrics**  
Velluto Velvet

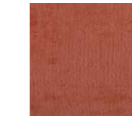

04250 Levante  
col.315

**Dettaglio piede**  
**Foot detail**



P 108  
H 20  
Piede in metallo  
verniciato  
Varnished metal  
frame

**Dettaglio lamiera**  
**Metal sheet detail**



H 5  
Elemento  
decorativo in  
metallo verniciato  
Painted metal  
decorative element

**Dettaglio cuscini**  
**Detail of the cushions**



**Finiture lamiera e piede metallo**  
**Metal sheet and foot finishings**

DI SERIE / STANDARD

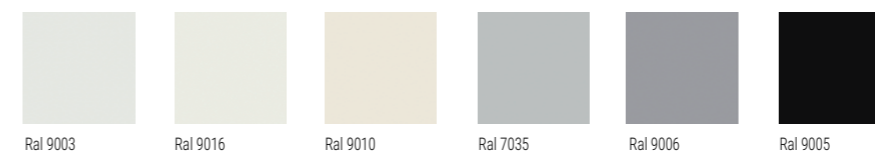

OPTIONAL



# Tilton



# Poltrone e pouf

## Armchairs and poufs

I complementi sono note virtuose che si  
espandono nell'ambiente perfezionandolo.

Accessories are virtuoso  
details that define  
any setting and hone  
it to perfection.

# 109



**Finiture fascia laminato**  
Laminated ring finishings

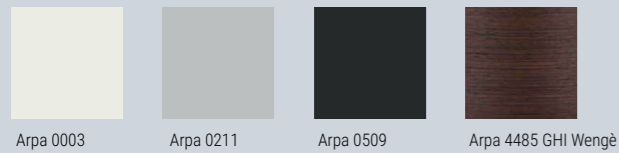

Struttura in legno di abete e multistrato di pioppo in vari spessori, cl. E1 a bassa emissione di formaldeide. Imbottitura in poliuretano espanso indeformabile in densità differenziate da 30 a 40 kg/m<sup>3</sup>, ovatta in poliester e piuma sintetica ecocompatibile. Elemento decorativo il laminato.

# Dinah

Fir wood and poplar plywood frame (thickness varies), cl. E1 low formaldehyde emission. Non-deformable polyurethane foam padding (densities vary from 30 to 40 kg/m<sup>3</sup>), polyester wadding and eco-friendly synthetic down. Decorative laminate element.

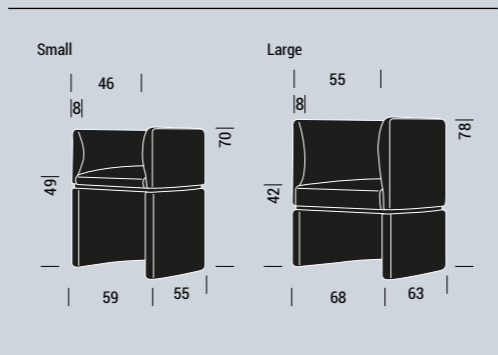

**Finiture base metallo**  
Metal base finishings

DI SERIE / STANDARD

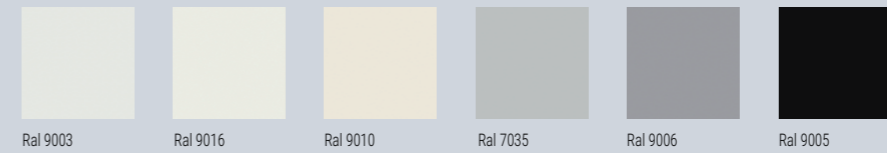

OPTIONAL

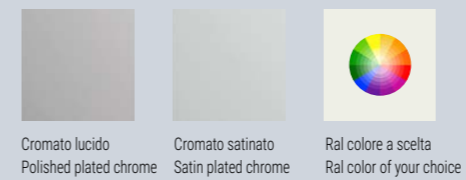

Struttura in legno di abete e multistrato di pioppo in vari spessori, cl. E1 a bassa emissione di formaldeide. Imbottitura in poliuretano espanso indeformabile in densità differenziate da 30 a 40 kg/m<sup>3</sup>, ovatta in poliester e piuma sintetica ecocompatibile. Base girevole in metallo.

# Parker

Fir wood and poplar plywood frame (thickness varies), cl. E1 low formaldehyde emission. Non-deformable polyurethane foam padding (densities vary from 30 to 40 kg/m<sup>3</sup>), polyester wadding and eco-friendly synthetic down. Metal swivel base.

**Dettaglio piede**  
Foot detail



B 01  
H 5

Base girevole in inox lucido e colonna in metallo cromato  
Swivel base in polished inox and column in plated chrome metal

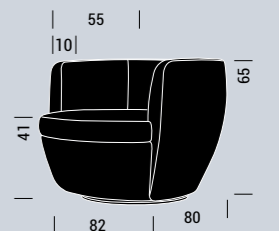



**Zoccolo laminato**  
Laminate plinth

DI SERIE / STANDARD

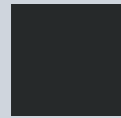

Arpa 0509

OPTIONAL



Arpa 0003



Arpa 0211

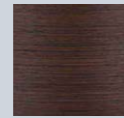

Arpa 4485 GHI Wengè

OPTIONAL



Arpa 2006 LUC  
Ottone lucido  
Polished brass



Arpa 2003 SAT  
Alluminio dorato  
satinato Satin  
golden aluminium



Arpa 2000 SAT  
Alluminio satinato  
Satin aluminium

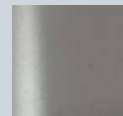

Arpa 2007 CT  
Canna di fucile cotton  
Cotton gunmetal

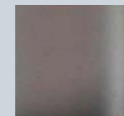

Arpa 2012 SAT  
ALU STEEL  
satinato satin



Arpa 2008 SAT  
Rame CA satinato  
Satin copper CA

**Tessuti**  
Fabrics

Velluto Velvet

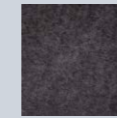

Barkley col.30

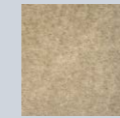

Barkley col.06

**Dettaglio piede**  
Foot detail



B 12  
H 5  
Zoccolo in laminato  
Arpa 0509  
Laminated wooden  
plinth Arpa 0509

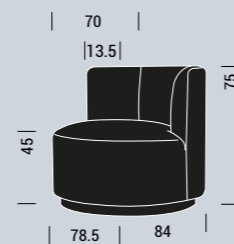

Struttura in legno di abete e multistrato di pino in vari spessori, cl. E1 a bassa emissione di formaldeide. Imbottitura in poliuretano espanso indeformabile in densità differenziate da 30 a 40 kg/m<sup>3</sup>, ovatta in poliestere e piuma sintetica ecocompatibile. Zoccolo in legno rivestito in laminato.

Fir wood and poplar plywood frame (thickness varies), cl. E1 low formaldehyde emission. Non-deformable polyurethane foam padding (densities vary from 30 to 40 kg/m<sup>3</sup>), polyester wadding and eco-friendly synthetic down. Wooden plinth clad with laminate.

# Duke



**Finiture piedi metallo**  
Metal feet finishings

DI SERIE / STANDARD

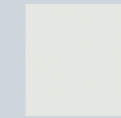

Ral 9003



Ral 9016



Ral 9010



Ral 7035

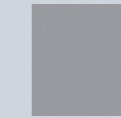

Ral 9006

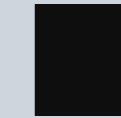

Ral 9005

OPTIONAL

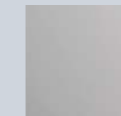

Cromato lucido  
Polished plated chrome



Cromato satinato  
Satin plated chrome



Ral colore a scelta  
Ral color of your choice

**Tessuti**  
Fabrics

Velluto Velvet

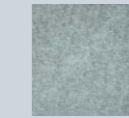

Barkley col.27

Pelle Leather



Lux col.2438

Velluto Velvet

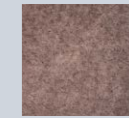

Barkley col.15

Pelle Leather

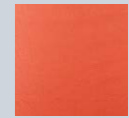

Lux col.2408

**Dettaglio piede**  
Foot detail



P 113  
H 22/18  
Piedi in metallo verniciato  
Varnished metal feet

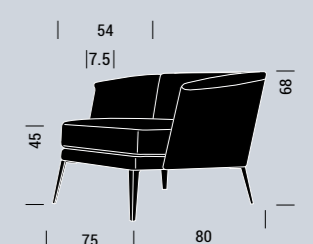

Struttura in legno di abete e multistrato di pino in vari spessori, cl. E1 a bassa emissione di formaldeide. Imbottitura in poliuretano espanso indeformabile in densità differenziate da 30 a 40 kg/m<sup>3</sup>, ovatta in poliestere e piuma sintetica ecocompatibile. Piedi in metallo.

Fir wood and poplar plywood frame (thickness varies), cl. E1 low formaldehyde emission. Non-deformable polyurethane foam padding (densities vary from 30 to 40 kg/m<sup>3</sup>), polyester wadding and eco-friendly synthetic down. Metal feet.

# Dizzy

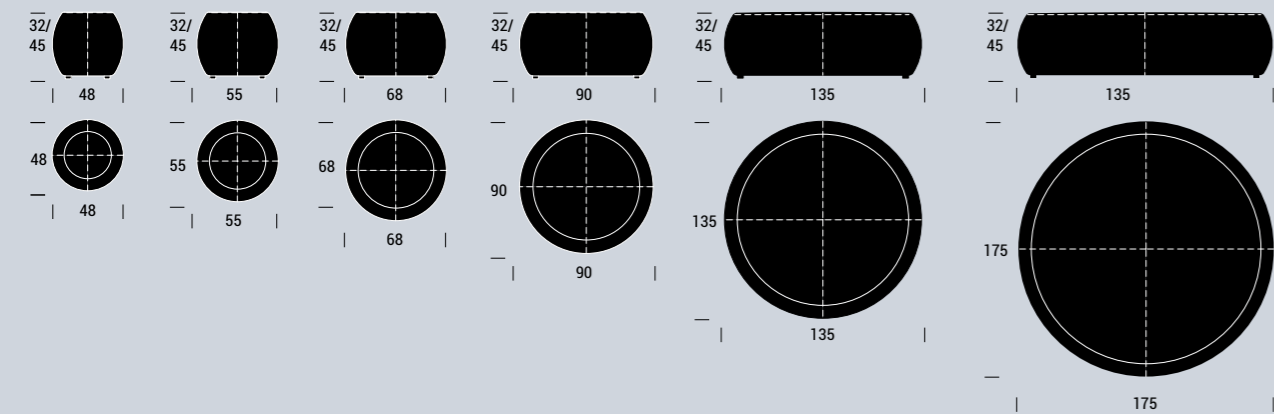
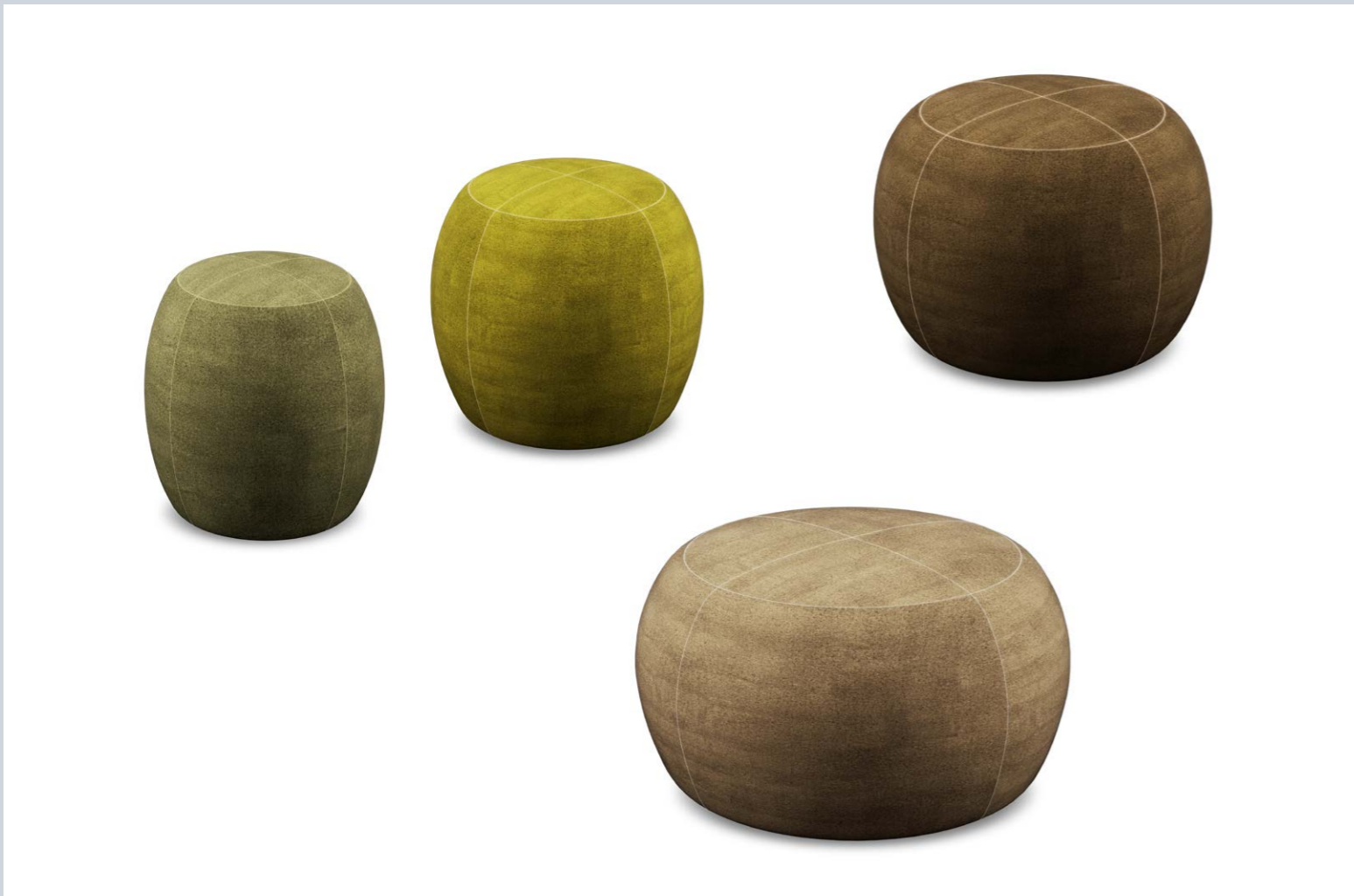

Struttura in legno di abete e multistrato di pioppo in vari spessori, cl. E1 a bassa emissione di formaldeide. Imbottitura in poliuretano espanso indeformabile in densità differenziate da 30 a 40 kg/m<sup>3</sup>, ovatta in poliestere e piuma sintetica ecocompatibile. Piedi a scomparsa.

# Billie

Fir wood and poplar plywood frame (thickness varies), cl. E1 low formaldehyde emission. Non-deformable polyurethane foam padding (densities vary from 30 to 40 kg/m<sup>3</sup>), polyester wadding and eco-friendly synthetic down. Retractable feet.

### Tessuti Fabrics

Velluto Velvet

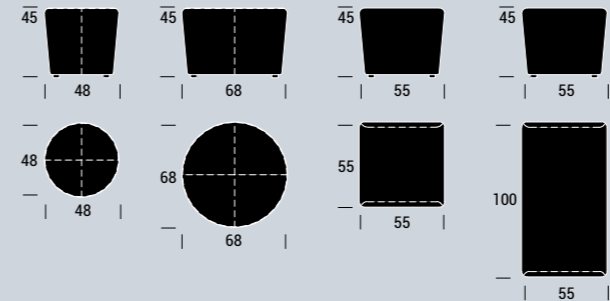
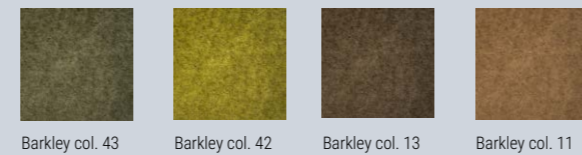

Struttura in legno di abete e multistrato di pioppo in vari spessori, cl. E1 a bassa emissione di formaldeide. Imbottitura in poliuretano espanso indeformabile in densità differenziate da 30 a 40 kg/m<sup>3</sup>, ovatta in poliestere e piuma sintetica ecocompatibile. Piedi a scomparsa.

# Frank

Fir wood and poplar plywood frame (thickness varies), cl. E1 low formaldehyde emission. Non-deformable polyurethane foam padding (densities vary from 30 to 40 kg/m<sup>3</sup>), polyester wadding and eco-friendly synthetic down. Retractable feet.

### Tessuti Fabrics

Velluto Velvet

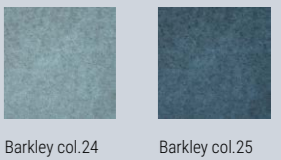





**Tessuti  
Fabrics**

Velluto Velvet



Barkley col.44

Barkley col.45

Struttura in legno di abete e multistrato di pioppo in vari spessori, cl. E1 a bassa emissione di formaldeide. Imbottitura in poliuretano espanso indeformabile in densità differenziate da 30 a 40 kg/m<sup>3</sup>, ovatta in poliestere e piuma sintetica ecocompatibile. Piedi a scomparsa.

# Joe

Fir wood and poplar plywood frame (thickness varies), cl. E1 low formaldehyde emission. Non-deformable polyurethane foam padding (densities vary from 30 to 40 kg/m<sup>3</sup>), polyester wadding and eco-friendly synthetic down. Retractable feet.

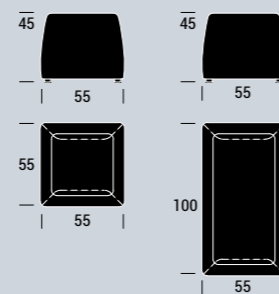



# Tavolini

## Small tables

L'originalità di un accessorio sta nel qui e ora, come un assolo improvvisato e inaspettato, di cui non si potrà più fare a meno.

The originality of an accessory lies in its hic et nunc. It is an impromptu and unexpected solo that you will never be able to do without.

# 119

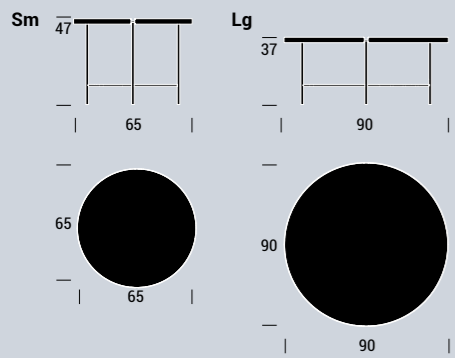

Struttura in metallo verniciato in colori di serie o optional oppure in finitura galvanica; piano in legno o vetro laccato.

Metal frame painted with standard or optional colors or galvanized finish; wooden or laquered top.

**Tabbal** design Luca Roccadadria

**Finiture struttura e cornice piano**  
Legs and top frame finishings

DI SERIE / STANDARD

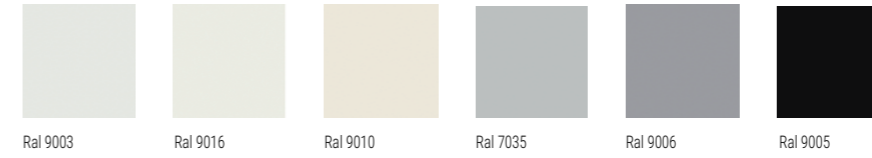

OPTIONAL



**Finiture piano legno**  
Wooden top finishings

DI SERIE / STANDARD

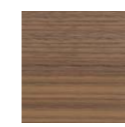

Noce Canaletto  
Canaletto walnut

OPTIONAL

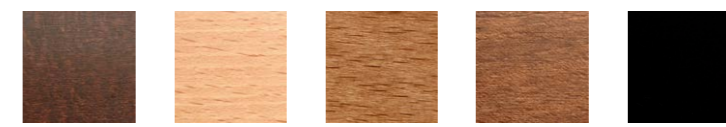

10  
Wengè

01  
Naturale Natural

04  
Noce chiaro  
Light walnut

05  
Noce Walnut

07/20  
Nero Black

**Finiture piano vetro laccato**  
Laquered glass top finishings

DI SERIE / STANDARD



Ral colore a scelta  
Ral color of your choice

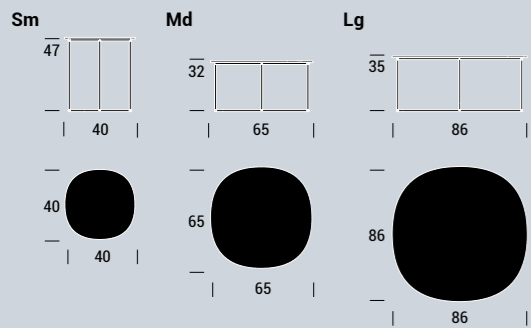

Struttura in metallo verniciato in colori di serie o optional oppure in finitura galvanica; piano in vetro laccato o ricotto.

Metal frame painted with standard or optional colors or galvanized finish; annealed glass or laquered glass top.

**Taborn** design Luca Roccadadria

**Finiture struttura metallo**  
**Metal frame finishings**

DI SERIE / STANDARD

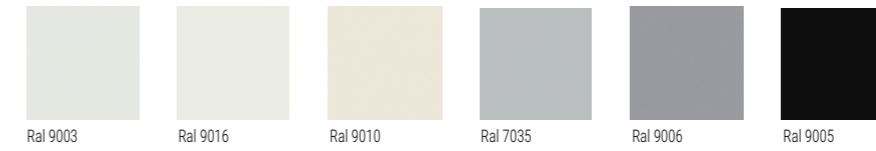

OPTIONAL



**Finiture piano vetro ricotto**  
**Annealed glass top finishings**

DI SERIE / STANDARD

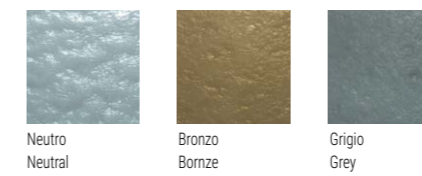

OPTIONAL



**Finiture piano vetro laccato**  
**Laquered glass top finishings**

DI SERIE / STANDARD

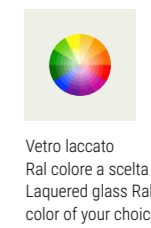

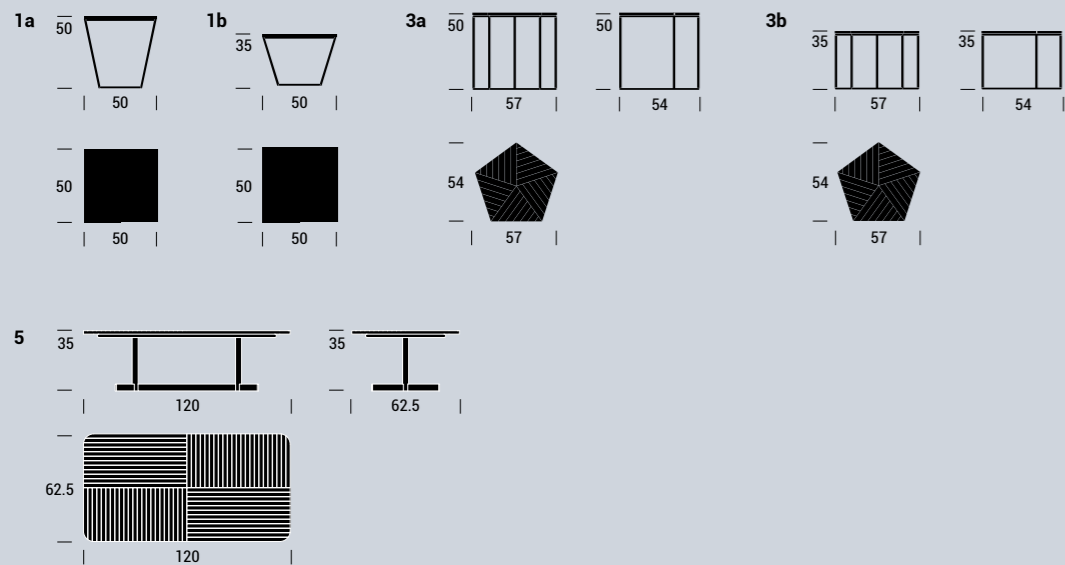

Struttura in metallo verniciato in colori di serie o optional oppure in finitura galvanica, piano in cemento stampato con scanalature riempite con innesto di vernice colorata o in marmo.

Metal frame painted with standard or optional colors or galvanized finish; stamped concrete top with grooves filled with colored paint graft or marble top.

# Priamo

design **Roberto Giacomucci**

## Finiture struttura metallo Metal frame finishings

DI SERIE / STANDARD

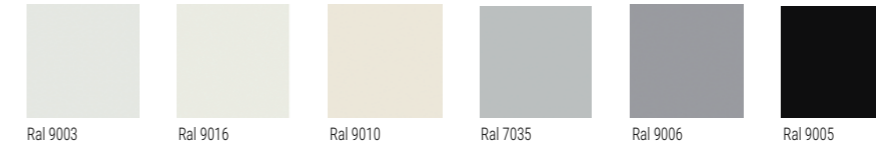

OPTIONAL



## Finitura piano in cemento Concrete top finishing



NCS-S 3500 N

## Colori fughe Joints colors



Ral colore a scelta  
Ral color of your choice

## Finiture piano marmo Marble top finishings



Bianco Carrara



Bianco Calacatta



Cappuccino

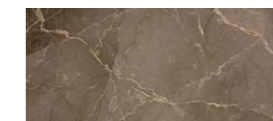

Moresco Imperiale

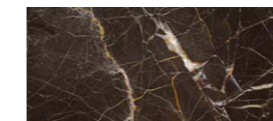

Noir Saint Laurent



Nero Marquina

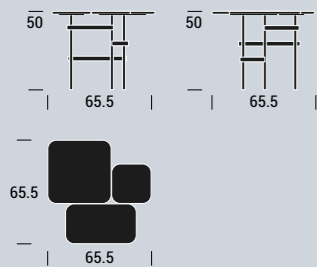

Struttura in metallo verniciato in colori di serie o optional oppure in finitura galvanica; piano in cemento stampato o in marmo.

Metal frame painted with standard or optional colors or galvanized finish; stamped concrete top or marble top.

# Tablette

design Roberto Giacomucci

## Finiture struttura metallo Metal frame finishings

DI SERIE / STANDARD

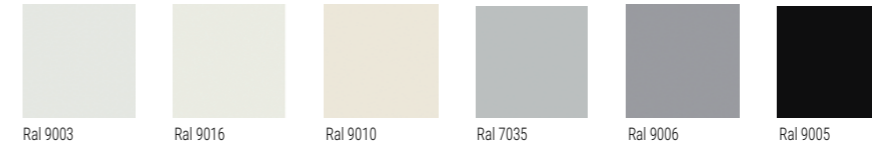

OPTIONAL



## Finiture piano cemento Concrete top finishing



Ral colore a scelta  
Ral color of your choice

## Finiture piano marmo Marble top finishings

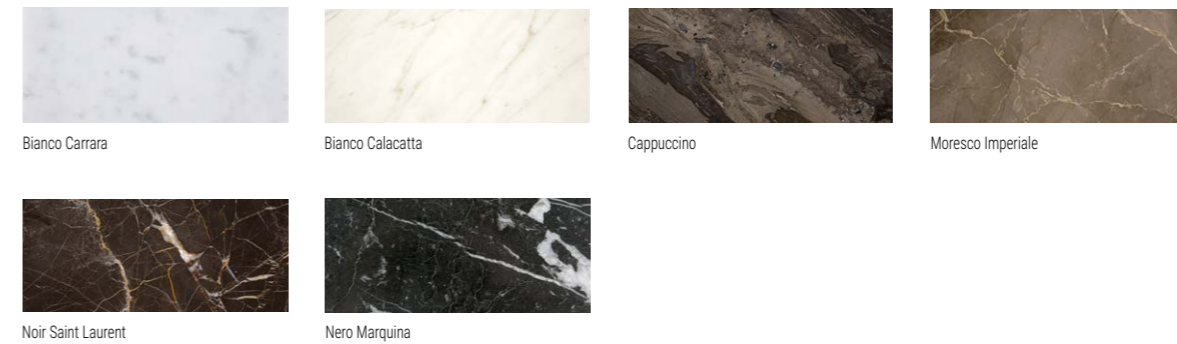



**Piano in vetro**  
glass top

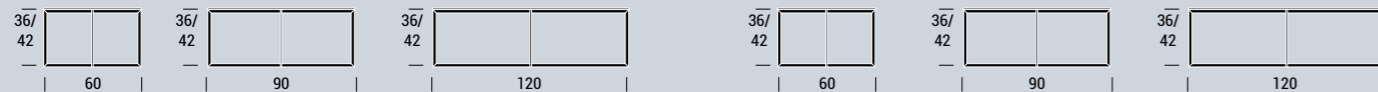

**Piano in marmo**  
marble top

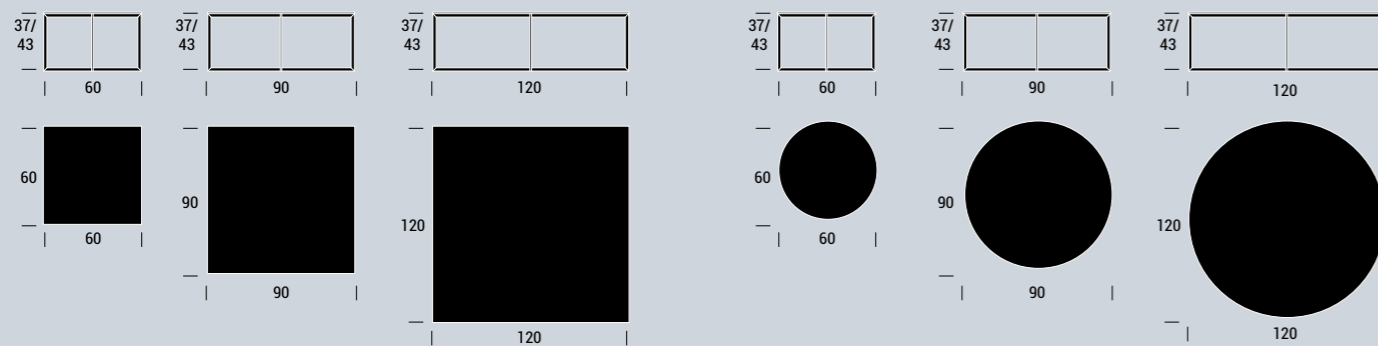

Struttura in metallo verniciato in colori di serie o optional oppure in finitura galvanica, piano in vetro o marmo.

Metal frame painted with standard or optional colors or galvanized finish; glass or marble top.

# Warhol

**Finiture struttura metallo**  
Metal frame finishings

DI SERIE / STANDARD



Ral 9016



Ral 9011



Cromato lucido  
Polished plated chrome

OPTIONAL



Ral colore a scelta  
Ral color of your choice

**Finiture piano vetro**  
Glass top finishings

DI SERIE / STANDARD



Vetro trasparente  
Transparent glass

OPTIONAL

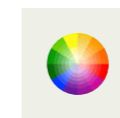

Vetro laccato  
Ral colore a scelta  
Laquered glass Ral  
color of your choice

**Finiture piano marmo**  
Marble top finishings



Bianco Carrara



Bianco Calacatta



Cappuccino

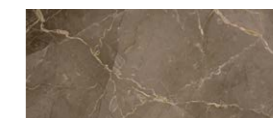

Moresco Imperiale

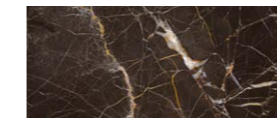

Noir Saint Laurent



Nero Marquina

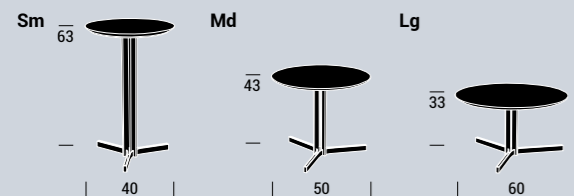

Struttura in metallo.  
 Finiture: versione ottone brunito verniciata a polveri, versioni ottone lucido e canna di fucile trattate con finitura galvanica e protezione trasparente. Piano in marmo naturale protetto con antimacchia, spessore 2 cm.

Metal frame.  
 Finishes: the burnished brass version features a powder-coated finish; the polished brass and gunmetal versions feature a galvanised finish with transparent protection. Stain-resistant, 2 cm-thick natural marble top.

**Ceo**

**Finiture struttura metallo**  
**Metal frame finishings**

DI SERIE / STANDARD

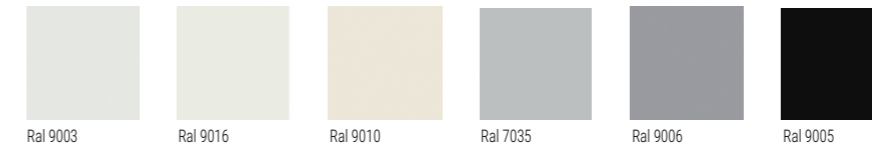

OPTIONAL

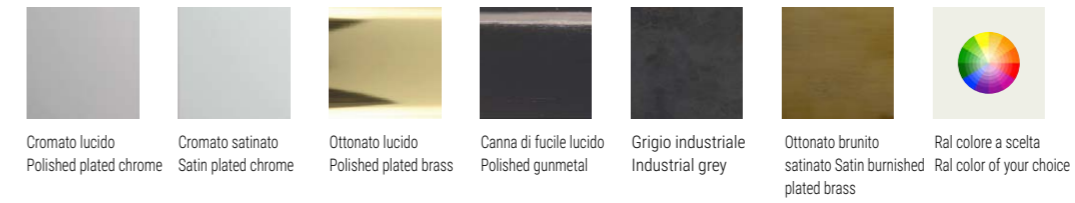

**Finiture piano marmo**  
**Marble top finishings**

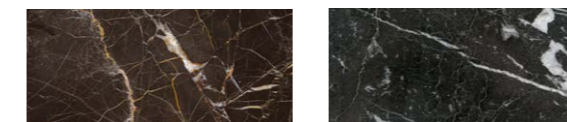
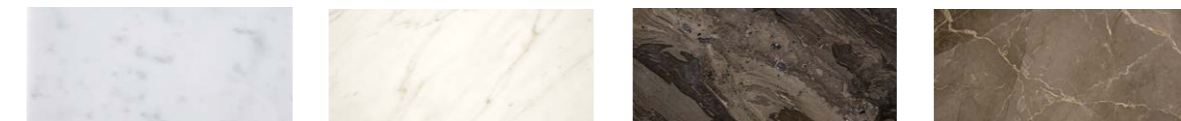

Noir Saint Laurent

Nero Marquina





**Tavoli/Tables**

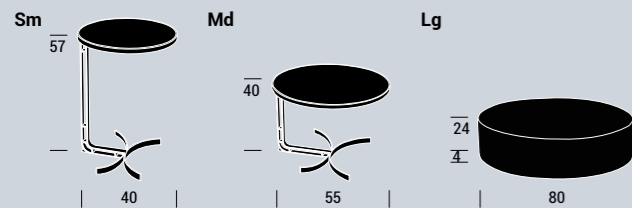

**Pouf**

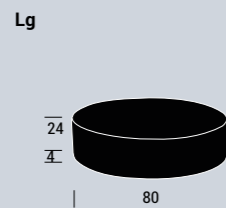

**Tessuti  
Fabrics**

Velluto Velvet

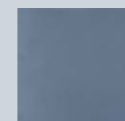

8336 col.55

Struttura in metallo.  
Finiture: versione ottone brunito verniciata a polveri, versioni ottone lucido e canna di fucile trattate con finitura galvanica e protezione trasparente.  
Piano in ceramica effetto marmo, spessore 6 mm ottenuto tramite cottura, spazzolatura e lucidatura meccanica. Superficie lucida, riflettente e antimacchia.

Metal frame.  
Finishes: the burnished brass version features a powder-coated finish; the polished brass and gunmetal versions feature a galvanised finish with transparent protection.  
6 mm-thick ceramic top with marble finish obtained by firing, brushing and mechanical polishing. Polished, reflective and stain-resistant surface.

**Febe**

**Finiture struttura metallo  
Metal frame finishings**

DI SERIE / STANDARD

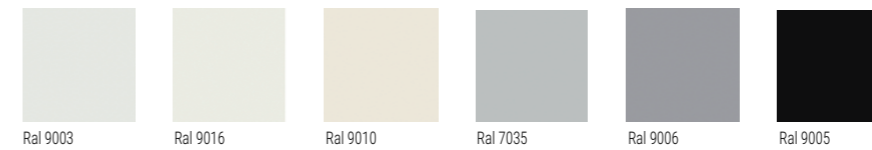

OPTIONAL

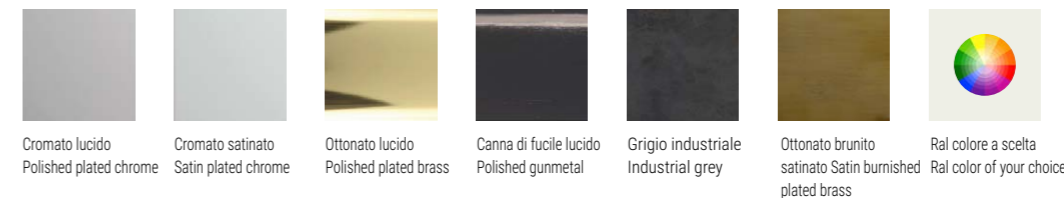

**Finiture piano marmo  
Marble top finishings**

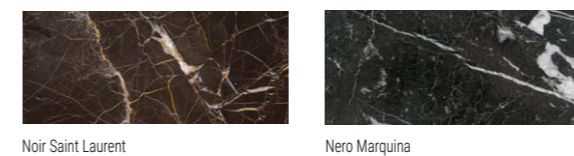
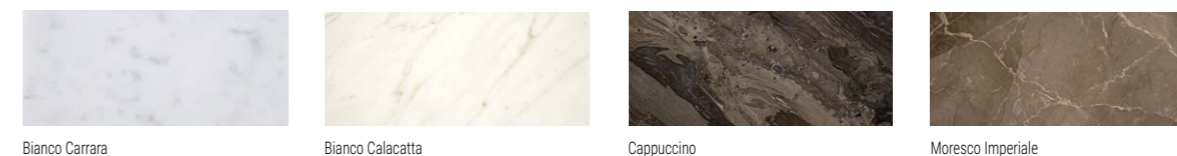

**Finiture piano ceramica  
Ceramic top finishings**

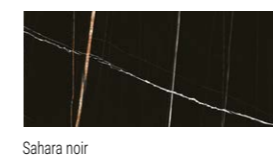
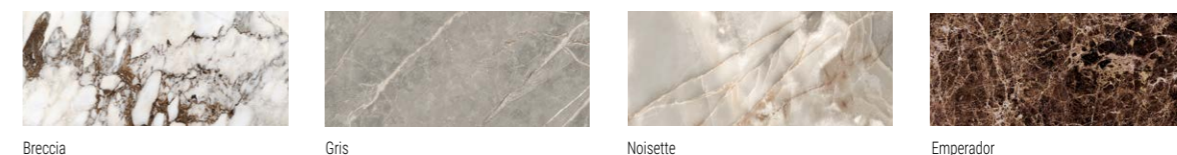

**Dettaglio piede pouf  
Foot pouf detail**



POUF  
P 59  
H 4  
Zoccolo multistrato laminato nero  
Plinth in black laminated plywood

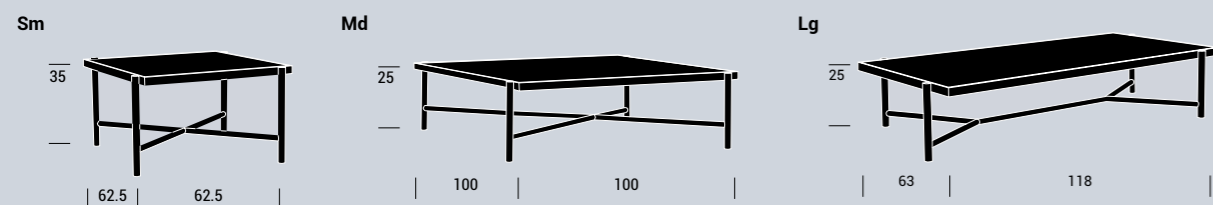

Struttura in metallo.  
 Finiture: versione ottone brunito verniciata a polveri, versioni ottone lucido e canna di fucile trattate con finitura galvanica e protezione trasparente. Piano in ceramica effetto marmo, spessore 6 mm ottenuto tramite cottura, spazzolatura e lucidatura meccanica. Superficie lucida, riflettente e antimacchia.

Metal frame.  
 Finishes: the burnished brass version features a powder-coated finish; the polished brass and gunmetal versions feature a galvanised finish with transparent protection. 6 mm-thick ceramic top with marble finish obtained by firing, brushing and mechanical polishing. Polished, reflective and stain-resistant surface.

# Rea

### Finiture struttura metallo Metal frame finishings

DI SERIE / STANDARD

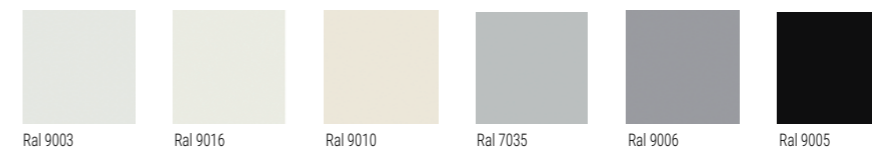

OPTIONAL



### Finiture piano marmo Marble top finishings

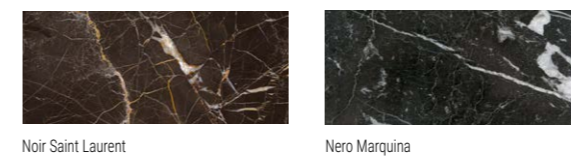
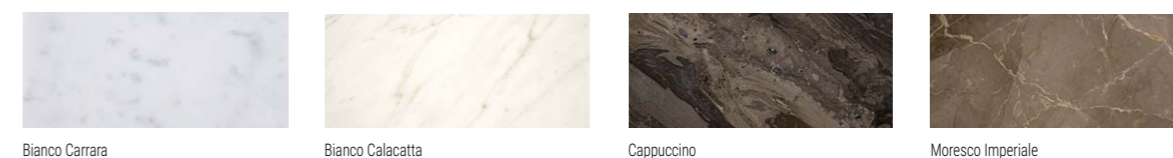

### Finiture piano ceramica Ceramic top finishings

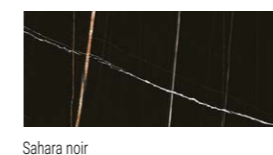

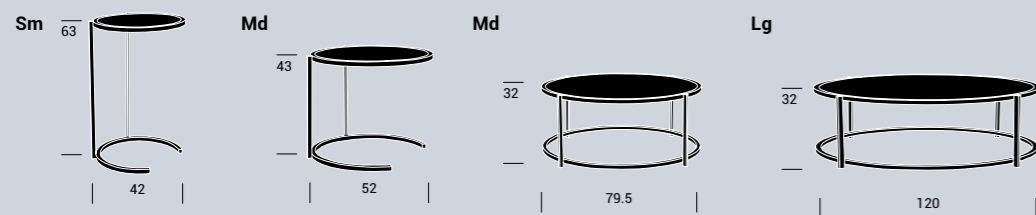

Struttura in metallo.  
 Finiture: versione ottone brunito verniciata a polveri, versioni ottone lucido e canna di fucile trattate con finitura galvanica e protezione trasparente. Piano in ceramica effetto marmo, spessore 6 mm ottenuto tramite cottura, spazzolatura e lucidatura meccanica. Superficie lucida, riflettente e antimacchia.

Metal frame.  
 Finishes: the burnished brass version features a powder-coated finish; the polished brass and gunmetal versions feature a galvanised finish with transparent protection. 6 mm-thick ceramic top with marble finish obtained by firing, brushing and mechanical polishing. Polished, reflective and stain-resistant surface.

**Teti**

**Finiture struttura metallo**  
**Metal frame finishings**

DI SERIE / STANDARD

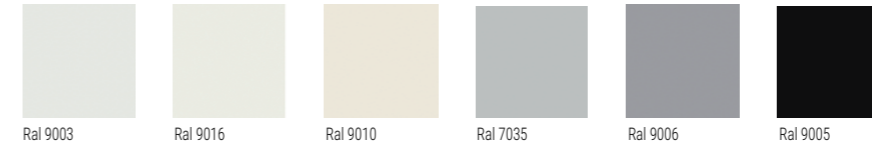

OPTIONAL



**Finiture piano marmo**  
**Marble top finishings**

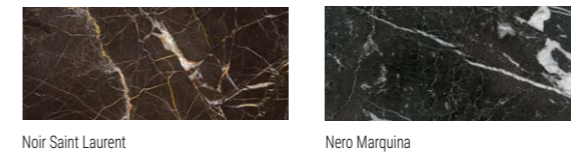
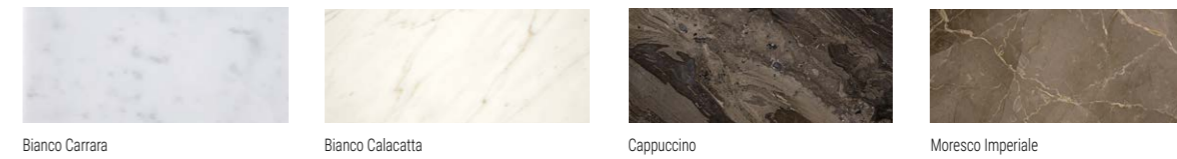

**Finiture piano ceramica**  
**Ceramic top finishings**

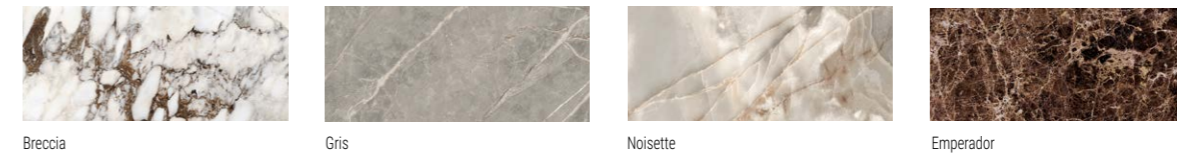



**Finitura struttura metallo**  
**Metal frame finishing**



Ral 9005

**Finitura piano vetro**  
**Glass top finishing**



Vetro temperato verniciato  
nero lucido coprente  
Tempered varnished polished  
black glass top

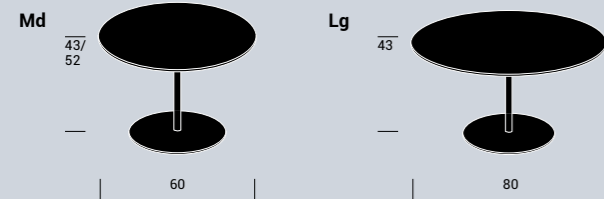

Struttura in metallo, piano in vetro verniciato  
nero.

Metal frame; black painted glass top.

# Zaikin

# DOMINGO®

Strada della Romagna, 285  
61121 PESARO (ITALY)  
T +39 0721 208080  
info@domingo.it  
www.domingo.it

Coordinamento generale Project management	<b>Valentina Bigiarini &amp; Francesca Grassi</b>
Grafica Graphic design	<b>ma:design Pesaro</b>
Foto Photo	<b>Mauro Foli Cervia</b>
Testi Texts	<b>Valentina Bigiarini</b>
Render	<b>EIDO</b> <b>Roccadadria</b> INDUSTRIAL DESIGN <b>Simone Roscini Cattolica</b>
Fotolito Litograph	<b>Lifeinpixel Pesaro</b>
Stampa Print	<b>Gruppo Leardini Fano</b>
Edizione 1 Issue 1	<b>Marzo 2023</b> <b>March 2023</b>

Diritti riservati. La riproduzione anche parziale è consentita solo previa autorizzazione scritta di Domingo Salotti s.r.l.  
All rights reserved. No parts of this catalogue may be reproduced without permission in writing from Domingo Salotti s.r.l.

Contemporary living

**domingo.it**